

H502E X4 DESIRE CAM PLUS

《H502E Quick Start Guide》

Version 2.0

Disclaimer & Warning

All users must read product operating instructions as well as this liability disclaimer before using any Hubsan product. By using a Hubsan product(s), users are accepting the terms and conditions of Hubsan liability and operational guidelines. This product is not suitable for minors under 14 years of age. While operating a Hubsan product(s), users also accept all liability and responsibility for their own behavior, actions as well as any consequences resulting thereof while using a Hubsan product(s). These products may only be used for purposes that are proper and in accordance with local regulations, terms and any applicable policies/guidelines Hubsan may make available. Users agree to comply with these terms and conditions, along with any and all relevant policies/guidelines set forth by Hubsan.

Instructions

Some product flight functions are restricted in certain areas. Once you use this product, you are deemed to have read carefully the relevant ICAO regulations, local airspace control provisions and the regulations governing UAVs. You assume all liability for any non-compliance with the foregoing, are responsible for the consequences for your actions as well as any indirect and/or direct liability that arises as a result of these limitations.

Flight environment requirements

- (1) Select an open environment devoid of high rise buildings and tall obstructions (such as trees and poles). Near buildings and obstacles, flight control signals and GPS signals can be severely weakened; GPS functions such as GPS mode and Return to Home may not function properly.
- (2) Do not fly in bad weather conditions (such as in wind, rain or fog).
- (3) Fly the drone in ambient temperatures of 0-40 °C.
- (4) When flying, please stay away from obstructions, crowds, high voltage lines, trees, water, etc.
- (5) To avoid remote control signal interference, do not fly in complex electromagnetic environments (such as venues with radio stations, power plants and towers).
- (6) The aircraft cannot be used in or near the Arctic circle or Antarctica.
- (7) Do not fly in no fly zones.
- (8) Do not operate the aircraft near high pressure lines, airports or areas with severe magnetic interference.

Aircraft + H907A Transmitter

Step 1

Binding the aircraft and transmitter:

Use this process if the aircraft and transmitter are not pairing automatically when powered on, or to reset the 2.4GHz flight control and 5.8GHz video transmission connections. The binding process is usually completed in the factory. If you replace either the remote or the aircraft, the two will need to be re-bound to each other.

Binding procedure:

1) Hold the Photo key and power on the transmitter until a flashing "H" appears on the screen.

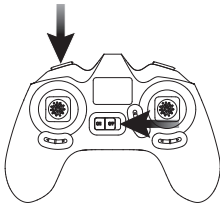

2) Release the Photo key when the screen changes to display "Bind to Plane". Power on the quad and place it very close to the transmitter. After a few seconds, the transmitter should then beep, indicating that binding has been successful.

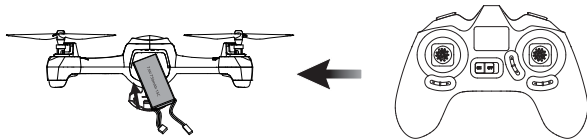

3) If this does not happen and the aircraft's LEDs begin to rotate clockwise, the binding is unsuccessful. Please power off the quad and repeat the above steps.

Step 2

Compass calibration

After the aircraft is powered on (and after a successful rebinding), the remote control/transmitter will ask you to calibrate the aircraft compass. This will happen every time you initialize the aircraft to fly it.

Calibration steps:

- 1) When the remote control screen reads "Set compass 1", slowly rotate the aircraft on the horizontal plane. The LEDs should be flashing clockwise.
- 2) When the remote control screen reads "Set compass 2", point the head of the aircraft downwards and rotate the aircraft in place (it should be vertical, pointing perpendicular to the ground). The LEDs should be flashing in vertical pairs, alternately.
- 3) When the "Set compass 2" disappears from the screen and the LEDs begin to flash simultaneously, calibration is complete.

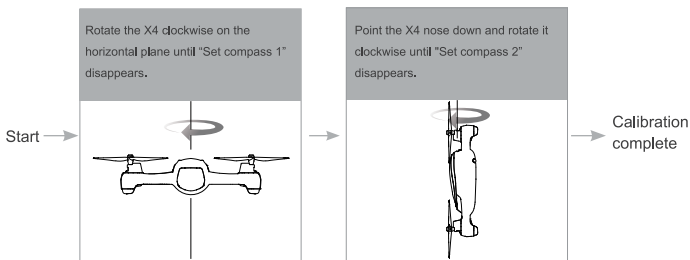

- Do not calibrate the compass in areas with strong magnetic interference.
- Do not carry ferromagnetic materials while calibrating the compass, such as keys, cell phones, etc.

Step 3

Taking off and Landing

The remote control is by default set to Mode 2 in factory; this manual will introduce flight operations in Mode 2.



Taking off

Slowly push the throttle joystick upwards to takeoff. Make sure you do so smoothly and firmly. Avoid jerky or erratic movements on the transmitter, as the aircraft may operate unstably in response.



Landing

Slowly and gently pull the throttle joystick down until the copter has completed its descent on the ground. Simultaneously pull the transmitter joysticks diagonally down-out to disarm the motors (as shown in the left figure). After all motors have come to a complete stop, release the joysticks.



- High speed propellers are very dangerous. Please keep the aircraft away from people, animate and inanimate objects.
- Keep the aircraft under control at all times while the motors are still running.
- Do not disarm during flight. The motors will stop in midair, causing the aircraft to fall and other such hazards. Only disarm during flight in the case of emergencies.

Installing and removing the propellers

The X4 aircraft uses 5.3-inch propellers. Each is marked with either an A or a B. Please replace damaged propellers. Before installing the propellers for the first time, please check whether the propeller and motor arm read "A" or "B". The two letters should match. Before installing propellers for the first time, please check that each Propeller A is matched with motor A and each Propeller B is matched with motor B. Align the "I" with the flat side of the "D" shaped motor shaft. Then use the provided screws and screwdriver to secure each propeller. Propeller A's are paired with black propeller screws and are tightened counterclockwise. Propeller B's are paired with silver propeller screws and are tightened clockwise. (as shown below)

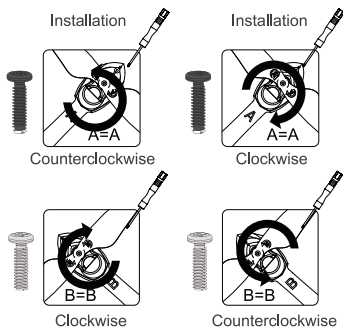
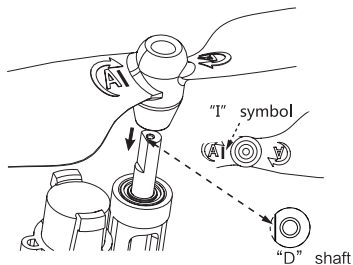

- Make sure that the propellers are installed in the correct positions (A to A, B to B), otherwise the aircraft will not be able to fly normally.
- Since the propeller blades are thin and somewhat sharp, it is recommended that users wear gloves during installation to prevent accidental scratches.

Charging and Installing the aircraft battery

The H502E aircraft is paired with a rechargeable 7.4v, 610mAh Li-Po battery. Be sure to use the provided Hubsan dedicated charger for charging. Fully charge the battery before flight. Connect the charger's USB adapter to a PC terminal and then the battery to the charger. Charging time is approximately 150min.

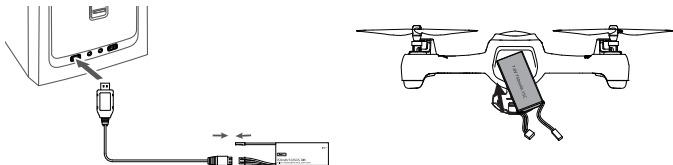

Installation: Push the battery into its compartment with its lines facing away from the unit. Connect it to the drone's power line and coil the power line into the battery compartment. Secure the compartment hatch.



- Make sure the battery is fully charged before each flight.
- Please do not leave unattended while charging.

Getting to know your H502E

Thank you for purchasing a HUBSAN product. The H502E is an easy to fly aircraft, capable of a variety of flight functions. Please read the manual carefully and follow all the instructions. Be sure to keep the manual for future reference.

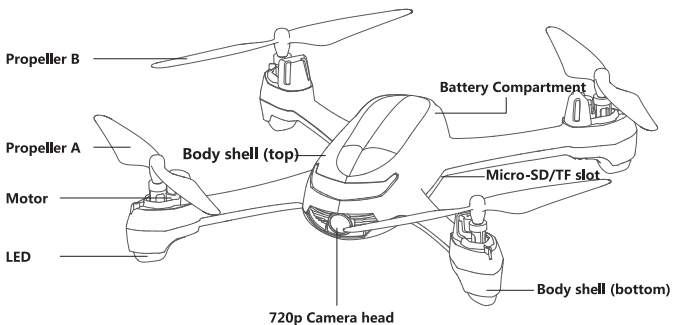

Hubsan Drones with GPS functions support GPS ,GALILEO, GLONASS total 3 types of GNSS work simultaneously.

Getting to know your H907A

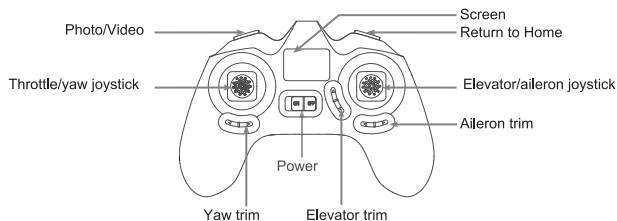
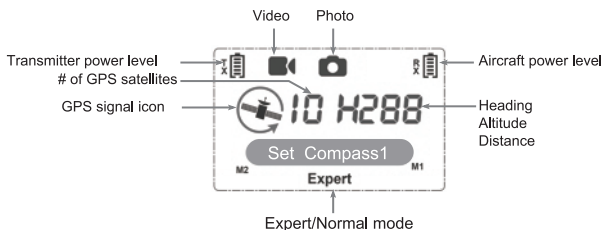

Mode 2 (American hand)

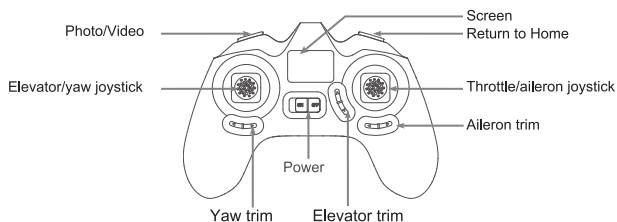

Mode 1 (Japanese hand)

Aircraft LED indications

The H502E has 4 LEDs; the fore/frontal LEDs are blue and the rear LEDs are red. The LED status indications are defined as follows:

Function	Status indication
Power on and start up	All 4 LEDs flash simultaneously
Compass calibration	Calib. compass 1, All 4 LEDs flash clockwise; Calib. compass 2, LEDs flash in vertical pairs, alternately
Horizontal calibration	All 4 LEDs are solidly lit
Flight mode	All 4 LEDs are solidly lit
Return to Home	Fore LEDs are solid blue and rear LEDs slowly flash red.
Low power	Fore/frontal blue LEDs stay solidly lit and the rear red LEDs flash rapidly
Photo	Rear LEDs (red) flash once
Video	Rear LED (red) flash alternately
LED on/off toggle	Long press the throttle trim to turn on/shut off the LEDs (the trim defaults to turn on)



- Before flying, carefully read the "Disclaimer and Safety Guidelines". Also watch the operational tutorial video on the official Hubsan website (www.hubsan.com).
- To learn more and for more detailed instructions, please download and read the "H502S+ User Manual" on the official Hubsan website.

H502E Frequently Asked Questions

1. Cannot arm motors

- 1) Check that you've passed compass calibration.
- 2) Confirm the transmitter to be operating in a normal manner.

2. Weak or nonexistent GPS signal/few or no GPS satellites

Make sure that the aircraft is not indoors or between buildings. Please take the aircraft outdoors to receive GPS satellites/signal.

3. The aircraft does not return to the home point

When the aircraft takes off, be sure that the aircraft has received 6 or more satellites.

4. The aircraft keeps on losing GPS satellites or GPS satellites drop to 0 erratically

Check to see whether there are sources of high-frequency signal interference around the aircraft (such as high-voltage lines, signal transmission towers, etc).

5. Aircraft/video feed is shaking/shaky

- 1) Check if the aircraft propellers are deformed or broken. Please replace them.
- 2) Check that all aircraft body screws are firmly in place.
- 3) Check whether any motor shafts are broken. Motors must be replaced if the shafts are broken.

6. Cannot take videos or pictures

- 1) Check to see that the SD card is installed in the aircraft prior to power on.
- 2) The SD card must be Class 10 or higher (recommended UHS-1), less than 64GB of storage (recommended 16GB) and formatted to FAT32. Make sure that the Allocation unit size is set to 32KB and that the Volume label area is blank.

Limitation of Liability

Hubsan accepts no liability for damages, injuries or any legal responsibilities incurred directly or indirectly from the use of Hubsan products under the following conditions:

1. Damages, injuries or any legal responsibilities incurred when users are drunk, under the influence of drugs or anesthesia, dizzy, fatigued, nauseous and/or affected by other conditions both physical and mental that could impair sound judgment and/or personal ability.
2. Subjective misjudgment and/or intentional mis-operation of products.
3. Any and all mental damage, trauma, impairment, illness, compensation caused/solicited by accidents involving Hubsan products.
4. Product operation in no-fly zones (i.e. natural reserves).
5. Malfunctions or problems caused by modification, refit, replacement or use with non-Hubsan accessories/parts, failure to follow the guidance of the manual in assembly or operation.
6. Damages, injuries or any legal responsibilities caused by mechanical failures due to natural wear and tear (aircraft flight time clocking in 100 hours or above), corrosion, aging hardware, etc.
7. Continued flight after low voltage protection alarms are triggered.
8. Knowingly flying aircraft under abnormal conditions (such as when water, oil, soil, sand or other unknown material are inside the X4, the aircraft and/or transmitter are incompletely assembled, the main components have obvious faults, obvious defect or missing accessories, etc).
9. Flying in the following situations and/or environments: areas with magnetic interference (such as high voltage lines, power stations, broadcasting towers and mobile base stations), radio interference, government regulated no-fly zones, if the pilot loses sight of the X4, suffers from poor eyesight or is otherwise unsuited for operating Hubsan products.
10. Aircraft use in or exposure to bad weather, such as a rain, wind, snow, hail, lightning, tornadoes and hurricanes.
11. Products are involved in/exposed to collisions, fire, explosions, floods, tsunamis, manmade and/or natural structure collapses, ice, avalanches, debris, landslides, earthquakes, etc.
12. The acquisition, through use of Hubsan products (specifically but not limited to aircraft), of any data, audio, video that results in infringement of law and/or rights.
13. Misuse and/or alteration of batteries, product/aircraft circuits, hardware protections (including protection circuits), RC model and battery chargers.
14. Any malfunction of equipment or accessory, including memory cards, that results in the failure of an image or video to be recorded or to be recorded in a way that is machine readable.
15. Users who engage in reckless, unsafe flying (with or without sufficient training).
16. Noncompliance with precautions, instructions, information and operation guidelines/methods given through official Hubsan website announcements, product quick start guides, user manuals, etc.

17. Other losses, damages, or injuries that are not within the boundaries of Hubsan responsibility.

RISK OF EXPLOSION IF BATTERY IS REPLACED BY AN INCORRECT TYPE.

DISPOSE OF USED BATTERIES ACCORDING TO THE LOCAL REGULATIONS.

HAZARDOUS MOVING PARTS KEEP FINGERS AND OTHER BODY PARTS AWAY.

Declaration of Conformity

Hereby, SHENZHEN HUBSAN TECHNOLOGY CO., LTD.,

declares this product is in compliance with the essential requirements and other relevant provisions of Directive 2014/53/EU. A copy of the original Declaration of Conformity can be obtained at the following address: 13th Floor, Bldg 1C, SHENZHEN NANSHAN SOFTWARE INDUSTRY BASE, Xuefu Road, Nanshan District, Shenzhen, China

This product bears the selective sorting symbol for waste electrical and electronic equipment (WEEE). This means that this product must be handled pursuant to European Directive 2012/19/EU in order to be recycled or dismantled to minimize its impact on the environment.

For further information, please contact your local or regional authorities. Electronic products not included in the selective sorting process are potentially dangerous for the environment and human health due to the presence of hazardous substances.

FCC INFORMATION

This equipment has been tested and found to comply with the limits for a Class B digital device, pursuant to Part 15 of the FCC Rules. These limits are designed to provide reasonable protection against harmful interference in a residential installation. This equipment generates, uses, and can radiate radio frequency energy and, if not installed and used in accordance with the instructions, may cause harmful interference to radio communications. However, there is no guarantee that interference will not occur in a particular installation. If this equipment does cause harmful interference to radio or television reception, which can be determined by turning the equipment off and on, the user is encouraged to try to correct the interference by one or more of the following measures:

- Reorient or relocate the receiving antenna.
- Increase the separation between the equipment and receiver.

- Connect the equipment into an outlet on a circuit different from that to which the receiver is connected.
- Consult the local dealer or an experienced radio/TV technician for help.

Changes or modifications not expressly approved by the party responsible for compliance could void the user's authority to operate the equipment.

This device complies with Part 15 of the FCC Rules. Operation is subject to the following two conditions: (1) this device may not cause harmful interference, and (2) this device must accept any interference received, including interference that may cause undesired operation.

Electrical and electronic equipment that are supplied with batteries (including internal batteries)

WEEE Directive & Product Disposal

At the end of its serviceable life, this product should not be treated as household or general waste. It should be handed over to the applicable collection point for the recycling of electrical and electronic equipment, or returned to the supplier for disposal.

Internal / Supplied Batteries.

This symbol on the battery indicates that the battery is to be collected separately.

This battery is designed for separate collection at an appropriate collection point.





Notice: Read the instruction manual carefully before use.
Propellers may cause injury; caution!

Warning: Do not leave the quadcopter charging unattended. Always disconnect the quadcopter from the charger immediately after charging is complete.
This is not a toy and is not suitable for children under 14.

www.HUBSAN.com

Product Name: X4 Desire
Product Standard Number: Q/HBS 001-2017
Vendor: Shenzhen Hubsan Technology Co., Ltd
Address: 13th Floor, Block C, Shenzhen Software Industrial Base,
Xuefu Road, Nanshan District, Shenzhen, Guangdong Province, China
Manufacturer: Dongguan Teng Sheng Industrial Co., Ltd.
Address: Dongguan City, Guangdong Province, Tangxia Tianke Branch
City Road, A22
Telephone: 0769-82776166 (China)



User Manual